

A large red graphic on the left side of the page, consisting of three downward-pointing chevrons stacked vertically. A vertical black line is positioned to the right of this graphic, separating it from the text.

**APC  
Redundant Switch**

**Installation and  
Operation Manual**

**APC<sup>®</sup>**

[www.APCturkey.com](http://www.APCturkey.com)

# Pre-Installation Procedures

---

## Receiving inspection

Inspect the package and contents for shipping damage, and make sure that all parts were sent. Report any damage immediately to the shipping agent, and report missing contents, damage, or other problems immediately to APC or your APC reseller.

## Please recycle



The shipping materials are recyclable. Please save them for later use, or dispose of them appropriately.

## Package contents

The package contains the following

- The Redundant Switch
- The Redundant Switch hardware kit (OM-8500):

Part Number	Description	Quantity
870-7190	Left Mounting Bracket	1
870-7191	Right Mounting Bracket	1
820-0022	Twist Locks	2
808-0004	Pan-head Phillips Screws with washers	4

- The 1U mounting rails
- The 1U mounting rails hardware Kit (OM-7600)

Part Number	Description	Quantity
810-0002	Ornamental Screw 10-32	4
810-2004	Snap-on Speed Nut 10-32	4
810-2008	Cage Nut 10-32	4

## Select the installation site

Choose a temperature-controlled area (0° – 50° C, 32° – 122° F), free of conductive contaminants.

# Available Models

---

Following is a rear view and basic information for each available Redundant Switch model.

## Model SU041

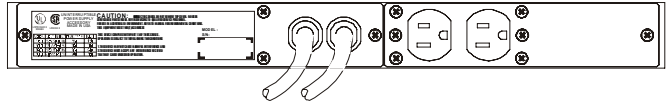

Voltage	Source (Input)	Load (Output)
1400 VA 120 V	2 NEMA 5-15	2 NEMA 15-5

## Model SU042-1

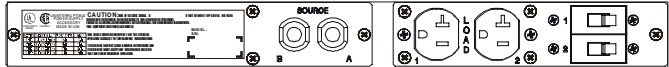

Voltage	Source (Input)	Load (Output)
3000 VA 120 V	2 NEMA L5-30	2 NEMA 5-20

For information on the circuit breaker safety device and load indicator for this model, see “Features of models SU042-1 and SU042-4” on page 5.

## Model SU042-2

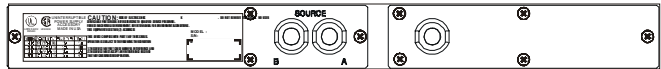

Voltage	Source (Input)	Load (Output)
3000 VA 120 V	2 NEMA L5-30	1 NEMA L5-30 (captive cord)

Available Models

**Model SU042-4**

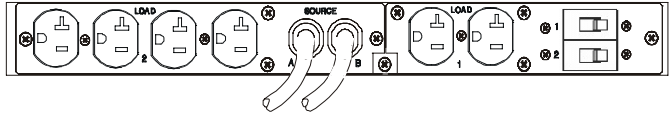

Voltage	Source (Input)	Load (Output)
3000 VA 120 V	2 NEMA L5-30	6 NEMA 5-20 (limited to 15 A from the circuit breaker)

For information on the circuit breaker safety device and load indicator for this model, see “Features of models SU042-1 and SU042-4” on page 5.

**Model SU043**



Voltage	Source (Input)	Load (Output)
1400 VA 230 V	2 IEC 320 C14	2 IEC 320 C13

**Model SU044-1**



Voltage	Source (Input)	Load (Output)
3000 VA 230 V	2 IEC 320 C20	1 IEC 320 C19 2 IEC 320 C13

**Model SU045-1**

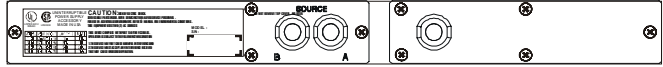

Voltage	Source (Input)	Load (Output)
3000 VA 208 V	2 NEMA L6-20	1 NEMA L6-20 (captive cord)

**Features of models SU042-1 and SU042-4**

**Safety device.** Models SU042-1 and SU042-4 have a red circuit breaker safety device attached to each circuit breaker switch.

**Do not remove this device.**

- The device prevents accidentally tripping of the circuit breaker, but allows the automatic tripping of the breaker that protects your equipment when an overload or malfunction occurs.
- To turn the circuit breaker off when necessary, pull the left end of the safety device forward so that it no longer blocks the switch, then push the switch to the OFF position.
- To reset a circuit breaker that has tripped automatically:
  - Pull the left end of the safety device forward so that it no longer blocks the switch.
  - Let the switch move fully to the left, then push it to the right.
  - Push the left end of the safety device back into place to block the switch.

**Outlet Control indicator.** The number to the left of each circuit breaker switch indicates which set of outlets it controls: LOAD 1 or LOAD 2.

# Installation

---

## Install management products and the UPS

1. Before you plug in the Redundant Switch and the two UPSs, install any compatible APC management products:
  - If you use a Web/SNMP Management Card, install it in the card slot of the preferred APC Smart-UPS, not in the card slot of the Redundant Switch.
  - Always use the card slot in the Redundant Switch for any other compatible APC management product, such as the Environmental Monitoring Card.



### Note

The Redundant Switch inlets are the main disconnect devices.

For multiple APC accessory configurations, visit the APC Web site

2. To install each UPS, follow the installation instructions in the *UPS User's Manual*.
  - Make sure both UPSs are the same sine-wave model.
  - Plug the power cords attached to the Redundant Switch into each UPS.

**Attach the brackets to the Redundant Switch**

Attach the two included brackets to the Redundant Switch. The following example shows how to attach the bracket for the right side. (Attach the left bracket in the same manner.)

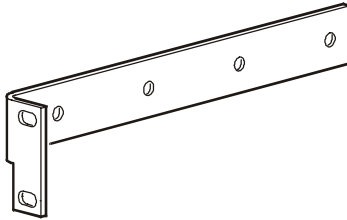

1. To allow space to route the cables and to place the connectors flush with the front of the rack, align the second hole from the front of the bracket with the first hole in the side of the Redundant Switch.

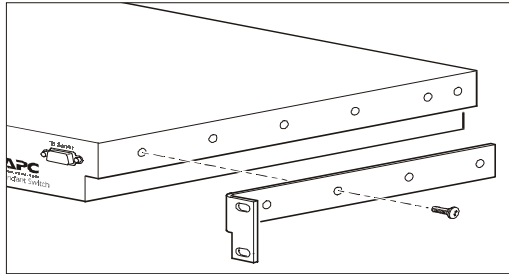

2. Insert and tighten the screws that are provided.

## Installation

### Install the rails (4-post rack only)

Mount the rails **only** if you are using a four-post rack. (In a two-post rack, you mount the Redundant Switch by the brackets alone.)

For information on which clips and screws your rack requires, see *Appendix A: Rack-Mount Supplement*.

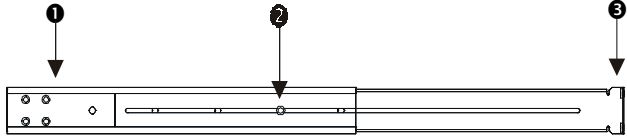

For a four-post rack:

1. Prepare the rack's rail-holes for mounting the brackets and rails of the Redundant Switch.
2. Disassemble each rail by removing the slide screw and nut **2**. Set aside the screw, nut, and front segment **1** of the rail.
3. Mount the end **3** of the rear segment of each rail to the rear rails on the prepared rack, using appropriate rack hardware.

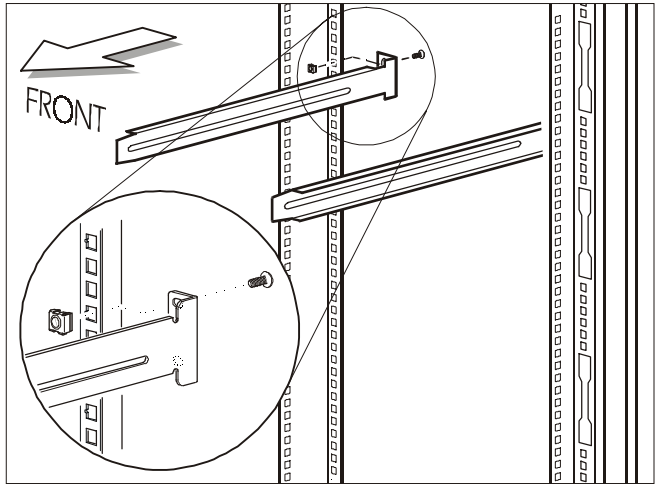

4. On each side, attach the front rail segment that you set aside in step 2 to the Redundant Switch.
  - a. Align the top two holes on the front rail segment with the two holes on the side (toward the rear) of the Redundant Switch.
  - b. Attach the rail segment with the tapered-head screws provided.

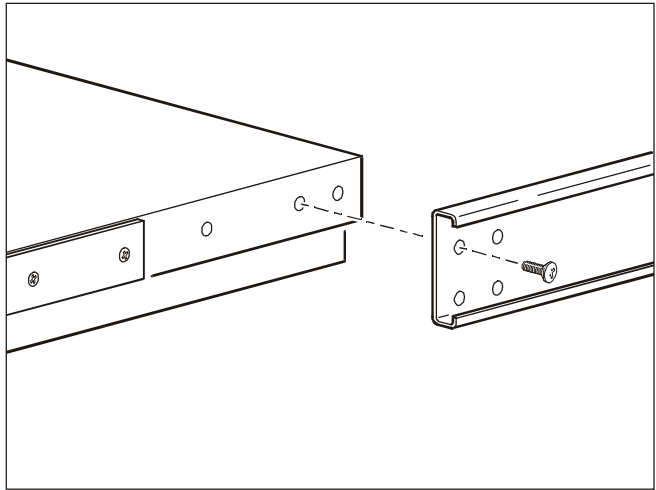

*Installation*

**Connect and route the cables**

1. To the front of the Redundant Switch, connect the communications cable and any accessory cables that require front connections.
2. Route the cables around the Redundant Switch through the side channel (marked with arrows below) to the equipment in the rack.

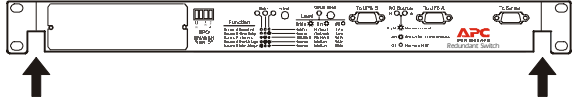

3. Optionally, install a plastic twist-lock (provided) on each side to secure the cables.

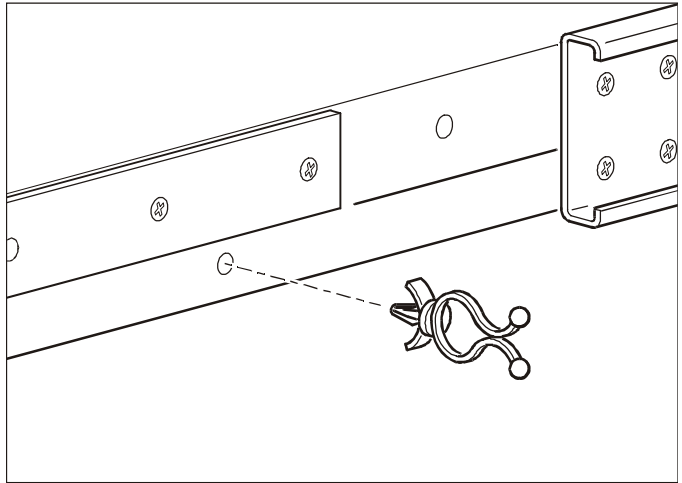

**Mount the Redundant Switch in the rack**



Use two people to lift the Redundant Switch.

1. Slide the front rail segments attached to the Redundant Switch into the rear rail segments attached to the rack.

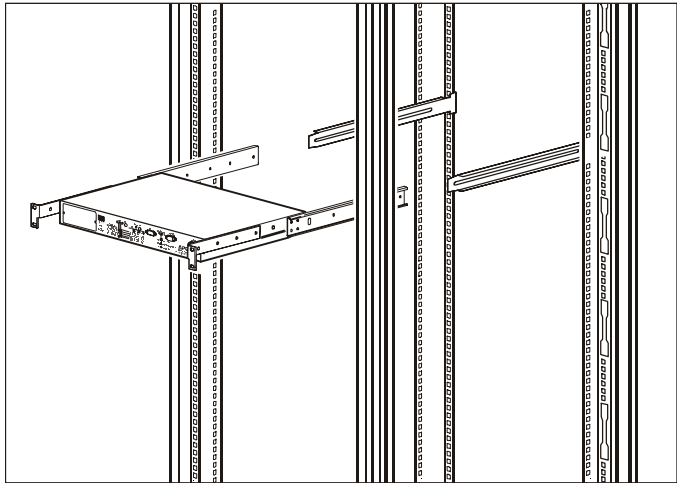

2. From the rear of the rack, insert and tighten the slide screws and nuts.

**Connect your equipment**



Do not connect laser printers through the Redundant Switch

1. Use your server's power cords to connect to the Redundant Switch.
2. Connect a communications cable (940-1000A) between each UPS and the Redundant Switch. Make sure that the communications cable and the power cord for the preferred UPS (UPS-A) are connected to the same UPS.



If there are not enough outlets to connect all your equipment, use a Rack-mount PDU, available through the APC Web site,

**Turn on the equipment and Redundant Switch**

1. Turn on all connected equipment.
2. To provide power to the equipment, press the ON button of UPS-A to turn on the Redundant Switch and UPS-B.
3. To test whether the cables are connected correctly, press the OFF button on one UPS.
  - If it turns back on, the cabling is correct.
  - If it does not turn back on, try swapping the two UPS communications cables to correct the problem.

**Connect the PowerChute® cable**

When you are ready to install PowerChute *plus*, install the PowerChute *plus* communications cable between the server port of the Redundant Switch and your server's serial port.



**Note**

To use PowerChute *plus* software to manage a Redundant Switch configuration, your server must be running Windows NT, Solaris, or NetWare. See your PowerChute *plus* documentation for the operating system versions that are supported.

# Configuration

---

## Supported configurations

Two supported configurations for Redundant Switch are shown below. For more information on these and other supported configurations, visit the APC Web site



### Note

Install only SNMP accessories in the UPS. You must install any other accessories in the Redundant Switch

Both UPSs must be the same sine-wave model.

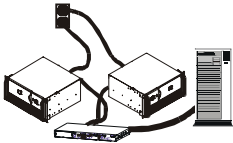
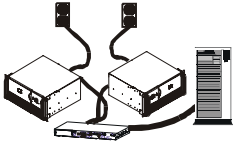
	<p><b>Minimum acceptable configuration:</b> Redundant Switch with two Smart-UPS units connected to one AC line (the same facility power source).</p>
	<p><b>Best configuration:</b> Redundant Switch with two Smart-UPS units connected to two separate AC lines (each UPS receiving power from a separate facility power source).</p>

## Configuring PowerChute plus

1. Install PowerChute *plus* as described in the enclosed software installation instructions.
2. For Source B:
  - a. At the Redundant Switch front panel, set the Source Preference to Source B.
  - b. Start the computer on which PowerChute *plus* is installed.
  - c. Start PowerChute *plus*. Communication is to UPS-B.
  - d. Configure UPS-B according to your requirements.
  - e. Set the UPSID to UPS\_B.
3. For Source A:
  - a. At the Redundant Switch front panel, set the Source Preference to Source A.

- b. Restart the computer on which PowerChute *plus* is installed.
- c. Start PowerChute *plus*. Communication is to UPS-A.
- d. Configure UPS-A according to your requirements.
- e. Set the UPSID to UPS\_A.

**When one UPS becomes unavailable**

When one of the two UPSs becomes unavailable to supply AC power, PowerChute *plus* sends the message “Self test failed: invalid test.” Any of the following conditions will cause the message to occur:

- A UPS self-test fails.
- Communication with the alternate UPS is lost.
- The voltage of the alternate UPS is out of range.
- UPS-A fails, and the Redundant Switch transfers the power input and PowerChute *plus* communication to UPS-B.

To regain high availability for your system, correct the problem as soon as possible. See “Troubleshooting” on page 18.



**Note**

When any self-test of the primary UPS occurs, the Redundant Switch switches power and communication to the other UPS, causes a self-test of that UPS, and then switches back. This is normal behavior.

# Operation

## Controls, LEDs, and ports on the front panel

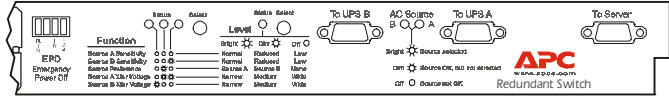

### Note

APC recommends the factory default settings among the settings shown below.

Function	LED Display	Description
Source A Sensitivity	Bright= Normal	Sets transfer sensitivity to line conditions
Source B Sensitivity	Dim (the factory default) = Reduced Off = low	
Source Preference	Bright = Source A (the factory default) Dim = Source B Off = none	Selects the preferred AC source
Source A Xfer Voltage	Bright = Narrow Dim = Medium (the factory default) Off = Wide	Sets the transfer voltage window (the range of acceptable voltage)
Source B Xfer Voltage		

**Emergency  
Power Off**

You can use a remotely operated Emergency Power Off (EPO) switch to turn off the UPS and disconnect power to the equipment load. When you turn off the UPS through the Emergency Power Off system, it will turn off immediately without switching to battery operation.



**Use only a licensed electrician to perform the following procedure to connect the Redundant Switch and its attached UPSs to your Emergency Power Off system.**

1. Use the EPO connector.
2. Use a normally-open contact to connect the +24 terminal to the IN terminal.
3. Wire the external blue four-pin female connector to the emergency power off system.

The EPO interface is a Safety Extra Low Voltage (SELV) circuit. Connect it only to other SELV circuits.



The EPO interface monitors circuits that have no determined voltage potential. Such closure circuits may be provided by a switch or relay properly isolated from the utility. To avoid damage to the Redundant Switch, do not connect the EPO interface to any circuit other than a closure type circuit.

## Front panel programmable settings

The following programmable settings are accessible using controls located on the Redundant Switch front panel.

**Function Select LED Indicator.** The three green Function Select LEDs indicate which user programmable parameter is selected for status display or modification. Use the left selection button to cycle through the five configurable items defined in “Controls, LEDs, and ports on the front panel” on page 15.

**Function Status LED Indicator.** The green Function Status LED indicates the state of the selected user programmable function. Use the Select button to cycle among the choices.

**AC Source LED Indicator.** The green online LED indicates the line quality and selection status of each source:

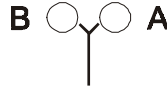

LED Display	Status of Source
Bright	Source is selected.
Dim	Source is OK, but not selected.
Off	Source is not OK.
One LED is flashing once per second, and the other LED is off	Both AC sources are out of tolerance.

**Source Sensitivity and Transfer Voltage.** APC recommends that you do not change these settings, which are correct for most conditions. See “Controls, LEDs, and ports on the front panel” on page 15.

# Troubleshooting

## Basic troubleshooting



**Only trained APC technicians should open the Redundant Switch for repair.**

Problem	Possible Cause	Corrective Actions
The Redundant Switch will not turn on.	Very low utility voltage, or no utility voltage.	Use a lamp with an incandescent bulb to test the AC power supply to the Redundant Switch. If the bulb lights very dimly or not at all, have the utility voltage checked. Ensure that the AC cables are properly connected between the Redundant Switch and the UPSs.
The server cannot communicate with the attached UPS through the Redundant Switch	A cabling problem or internal Redundant Switch fault	Ensure that all cables connections are securely connected. If there is still no communication, connect the server directly to a UPS. If you can establish communication by this direct connection, there is an internal Redundant Switch fault. Contact APC Customer Support.
All Redundant Switch LEDs are flashing	An Internal, automated self-test failure occurred; the Redundant Switch is defective.	See “Obtaining service” on page 25.

For computer interface port specifications, see the APC Web

**Troubleshooting communications and lost redundancy**

With the high availability system, the attached UPSs are polled continuously for capability to carry a load and ability to communicate with the management software (PowerChute *plus*). When a problem with one of the UPSs occurs, power to the load is not interrupted and polling continues, and PowerChute *plus* responds by displaying the message, “Self test failed: invalid test.”

**Communications Problems.** If the message “Self test failed: invalid test.” occurs repeatedly:

1. Check the communications path between the UPSs and the Redundant Switch.
2. Check the front panel of the Redundant Switch.
  - If the Status Select LEDs are flashing in any sequence, the Redundant Switch has failed. See “Basic troubleshooting” on page 18.
  - If the front panel appears normal, there may be a UPS or server communications problem, See the troubleshooting and service sections of your UPS manuals.
  - If you need more help, contact APC Worldwide Customer Support.

**Loss of Redundancy.** If the Redundant Switch LED for UPS-B is off, UPS-B has lost the ability to provide power to the equipment load when engaged. If the LED for UPS-A is off, UPS-A has failed, and power is now provided by UPS-B. See the troubleshooting and service sections of your UPS manuals.

If PowerChute *plus* displays the message “self test failed: invalid test” briefly or several times, the output voltage of UPS-A has dropped. Perform a UPS self-test through PowerChute *plus*.

- If the self test fails, see the troubleshooting and service sections of your UPS manuals.
- If you need more help, contact APC Worldwide Customer Support.

# Specifications

SU041,  
SU042-1,  
SU042-2, and  
SU042-4

Item	Specification
<b>Power</b>	
Nominal input voltage	120VAC
Input voltage range	0 – 165 VAC
Frequency range	47 – 63 Hz
Normal sensitivity transfer times	8 ms maximum at 60 Hz 10 ms maximum at 50 Hz
Reduced sensitivity transfer times	16 ms maximum at 60 Hz 20 ms maximum at 50 Hz
Maximum current draw	12 A (SU041 model) 24 A (SU042 models)
<b>Physical</b>	
Size:	1.75 × 17.0 × 7.5 in 4.45 × 43.2 × 19 cm
Net weight	10 lb (4.5 kg)
Shipping weight	15 lb (6.8 kg)
<b>Environmental</b>	
Elevation (above MSL): • Operating • Storage	0 to 10,000 ft (0 to 3000 m) 0 to 50,000 ft (0 to 1500 m)
Temperature: • Operating • Storage	32° to 122° F (0 to 50° C) 5° to 122° F (– 15° to 50° C)
Relative Humidity (Operating and Storage)	0 to 95%, non-condensing
<b>Approvals/Standards</b>	
UL, CSA, FCC Class A	

**SU043 and  
SU044-1**

<b>Item</b>	<b>Specification</b>
<b>Power</b>	
Nominal input voltage	230 VAC
Input voltage range	0 – 325 VAC
Frequency range	47 – 63 Hz
Normal sensitivity transfer times	4 ms typical, 8 ms maximum at 60 Hz 5 ms typical, 10 ms maximum at 50 Hz
Reduced sensitivity transfer times	8 ms typical, 16 ms maximum at 60 Hz 10 ms typical, 20 ms maximum at 50 Hz
Maximum current draw	6A (SU043 model) 13A (SU044-1 model)
<b>Physical</b>	
Size:	1.75 × 17.0 × 7.5 in 4.45 × 43.2 × 19 cm
Net weight	10 lb (4.5 kg)
Shipping weight	15 lb (6.8 kg)
<b>Environmental</b>	
Elevation (above MSL): • Operating • Storage	0 to 10,000 ft (0 to 3000 m) 0 to 50,000 ft (0 to 1500 m)
Temperature: • Operating • Storage	32° to 122° F (0 to 50° C) 5° to 122° F (– 15° to 50° C)
Relative Humidity (Operating and Storage)	0 to 95%, non-condensing
<b>Approvals/Standards</b>	
CE, VDE, EN55022, EN55024	

**SU045**

<b>Item</b>	<b>Specification</b>
<b>Power</b>	
Nominal input voltage	208 VAC
Input voltage range	0 – 275 VAC
Frequency range	47 – 63 Hz
Normal sensitivity transfer times	4 ms typical, 8 ms maximum at 60 Hz 5 ms typical, 10 ms maximum at 50 Hz
Reduced sensitivity transfer times	8 ms typical, 16 ms maximum at 60 Hz 10 ms typical, 20 ms maximum at 50 Hz
Maximum current draw	14 A
<b>Physical</b>	
Size:	1.75 × 17.0 × 7.5 in 4.45 × 43.2 × 19 cm
Net weight	10 lb (4.5 kg)
Shipping weight	15 lb (6.8 kg)
<b>Environmental</b>	
Elevation (above MSL): • Operating • Storage	0 to 10,000 ft (0 to 3000 m) 0 to 50,000 ft (0 to 1500 m)
Temperature: • Operating • Storage	32° to 122° F (0 to 50° C) 5° to 122° F (– 15° to 50° C)
Relative Humidity (Operating and Storage)	0 to 95%, non-condensing
<b>Approvals/Standards</b>	
UL, CSA, FCC Class A	

# Appendix A: Rack-Mount Supplement

---

## **Installation for rack-mount units**

The Redundant Switch is provided with brackets for mounting in standard 19 in.(46.5 cm.) rack.

Select a rack location with adequate air flow that is free from excessive dust. Do not operate the Redundant Switch where temperature or humidity are outside the limits listed under “Specifications,” beginning on page 20.

**Rail hardware** Different types of racks require different rail hardware.

Type of Rack	Hole Type	Hardware Required
Equipment Rack: usually an open rack	Threaded or not threaded	For threaded holes, see rack specifications. Threaded holes do not require nuts. For non-threaded holes, use APC hardware provided.
APC NetShelter <sup>®</sup> , Compaq <sup>®</sup> , IBM <sup>®</sup> , Dell <sup>®</sup> , Vero <sup>®</sup> , Rittal <sup>®</sup> : enclosures	Square	Cage nuts: 10-32 internal thread, APC part number 810-2008. (See below.) Screws: 10-32 thread, Phillips head, APC part number 810-0002.
Hewlett Packard: enclosure	Round	Clip nuts: 10-32 internal thread, APC part number 810-2004. (See below.) Screws: 10-32 thread, Phillips head. APC part number 810-0002.
Telecommunications open rack with 2 or 4 poles	Threaded	See rack specification. No hardware provided by APC.

The following APC clip nuts and cage nuts, mentioned in the preceding table, are provided with the Redundant Switch:

- Clip Nut (810-2004)

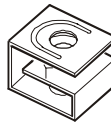

- Cage Nut (810-2008)

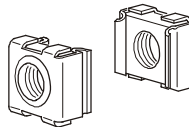

# Warranty and Service

---

## Limited warranty

APC warrants the Redundant Switch to be free from defects in materials and workmanship for a period of two years from the date of purchase. Its obligation under this warranty is limited to repairing or replacing, at its own sole option, any such defective products. This warranty does not apply to equipment that has been damaged by accident, negligence, or misapplication or has been altered or modified in any way. This warranty applies only to the original purchaser.

## Warranty limitations

**Except as provided herein, APC makes no warranties, express or implied, including warranties of merchantability and fitness for a particular purpose.** Some jurisdictions do not permit limitation or exclusion of implied warranties; therefore, the aforesaid limitation(s) or exclusion(s) may not apply to the purchaser.

**Except as provided above, in no event will APC be liable for direct, indirect, special, incidental, or consequential damages arising out of the use of this product, even if advised of the possibility of such damage.**

Specifically, APC is not liable for any costs, such as lost profits or revenue, loss of equipment, loss of use of equipment, loss of software, loss of data, costs of substitutes, claims by third parties, or otherwise. This warranty gives you specific legal rights and you may also have other rights, which vary according to jurisdiction.

## Obtaining service

To obtain support for problems with your Redundant Switch:

1. Note the serial number and date of purchase. The serial number is located on the back of the Redundant Switch.
2. Contact Customer Support at a phone number on the back cover of this document. A technician will try to help you solve the problem by phone.
3. If you must return the product, the technician will give you a return material authorization (RMA) number. If the warranty expired, you will be charged for repair or

replacement.

4. Pack the unit carefully. The warranty does not cover damage sustained in transit. Enclose a letter with your name, address, RMA number and daytime phone number; a copy of the sales receipt; and a check as payment, if applicable.
5. Mark the RMA number clearly on the outside of the shipping carton.
6. Ship by insured, prepaid carrier to the address provided by the Customer Support technician.

# Radio Frequency Interference

---



**Changes or modifications to this unit not expressly approved by the party responsible for compliance could void the user's authority to operate this equipment.**

This equipment has been tested and found to comply with the limits for a Class A digital device, pursuant to part 15 of the FCC Rules. These limits are designed to provide reasonable protection against harmful interference when the equipment is operated in a commercial environment. This equipment generates, uses, and can radiate radio frequency energy and, if not installed and used in accordance with this user manual, may cause harmful interference to radio communications. Operation of this equipment in a residential area is likely to cause harmful interference. The user will bear sole responsibility for correcting such interference.

This Class A digital apparatus complies with Canadian ICES-003.

*Cet appareil numérique de la classe A est conforme à la norme NMB-003 du Canada.*

[www.APCturkey.com](http://www.APCturkey.com)